

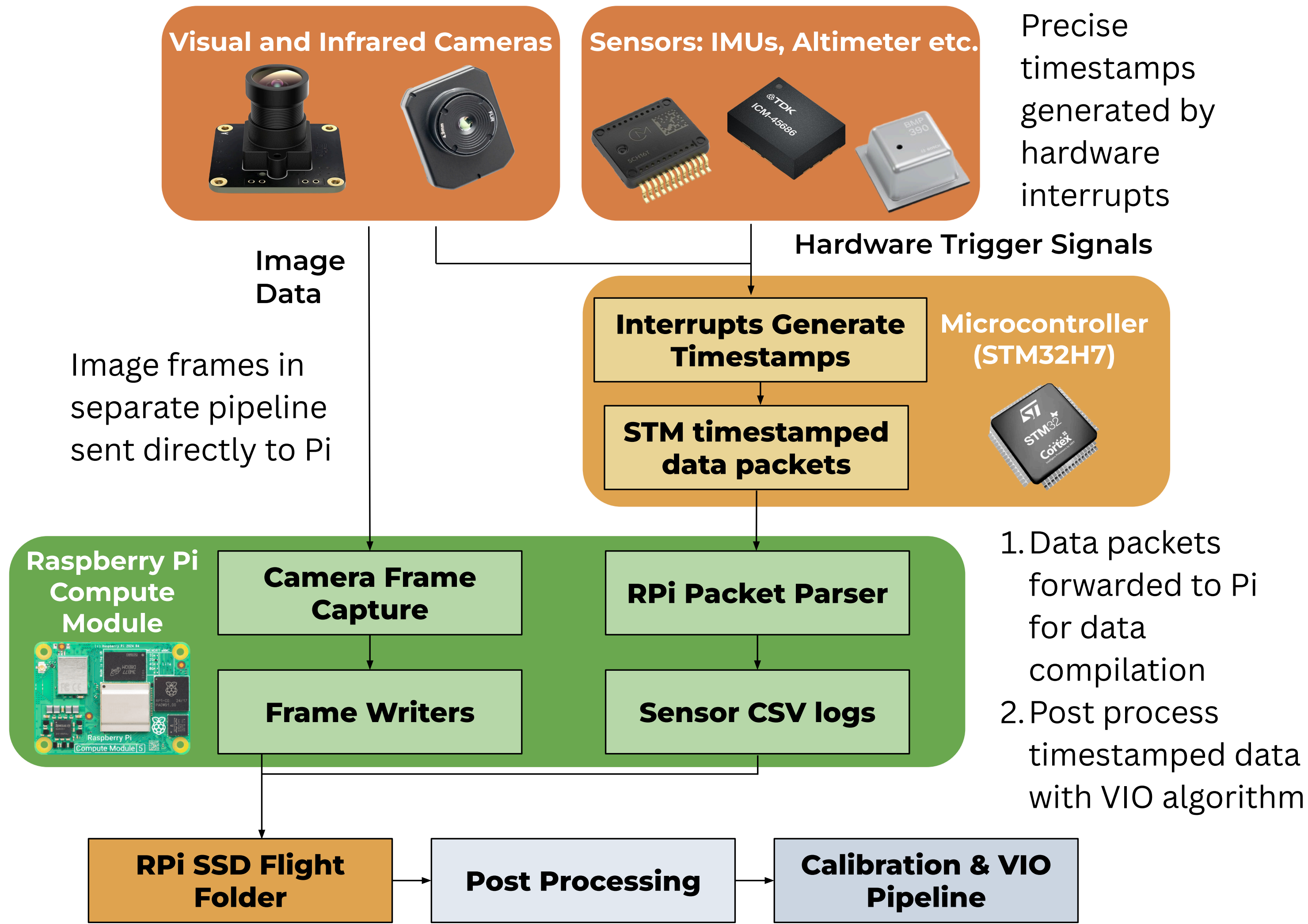

VIPER: Technical Systems Breakdown

Samina Farheen | Noah Venegas | Wesley Zalvin | Carter Brown | Eugene Antone
Andrew Hariman | Annie Do | Nicholas Carrano | Andrew Mills | William Tu

Sensor Dataflow



Thermal Management

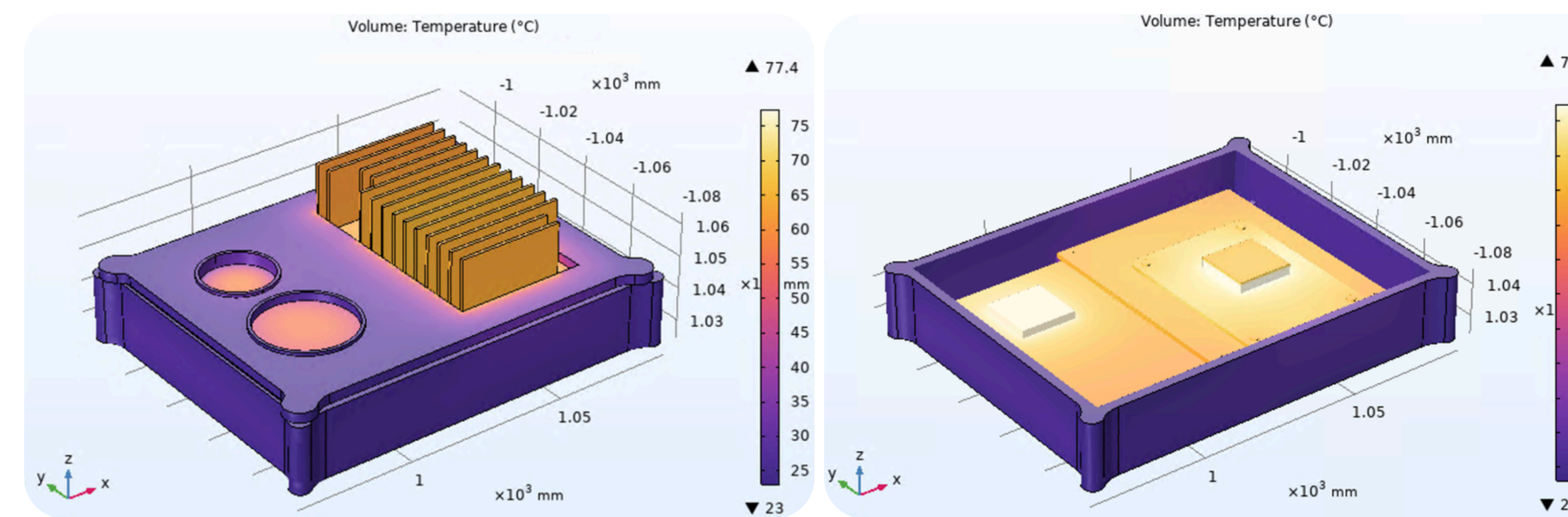

- Custom heat sink designed to drop the main processor temperature by 40% and optimize weight by 56%
- Thermal vias built into the PCB design to heat sink Boson
- Thermal validation testing reveals that the simulation results were within 5 degrees Celsius of observed results

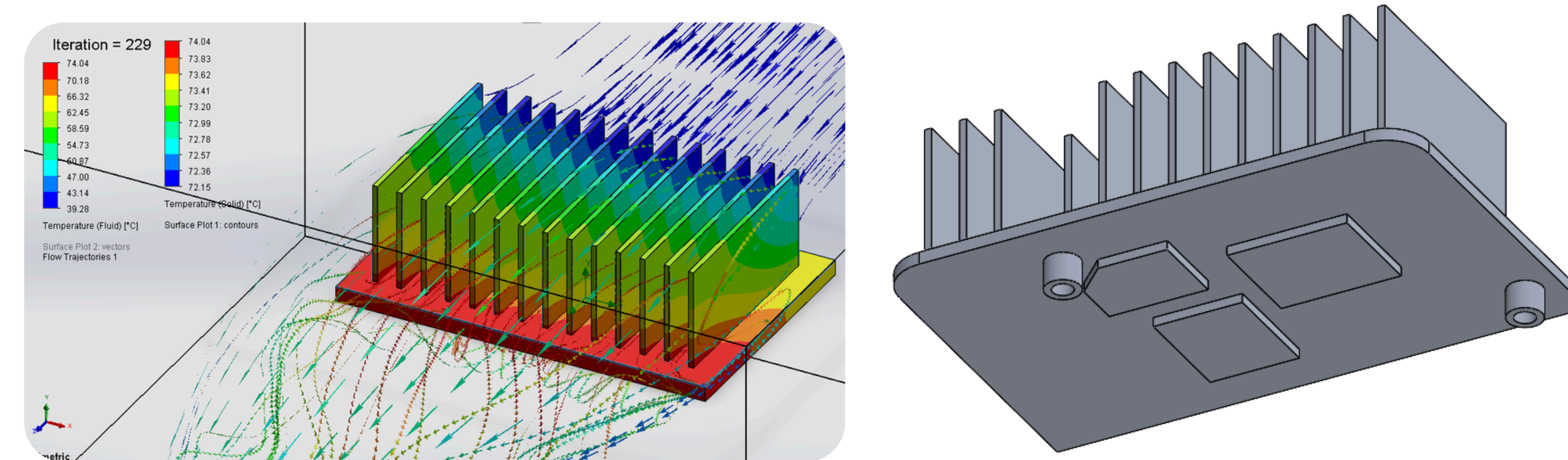

Flight Testing



- Day and nighttime testing were conducted to validate VIPER's ability to operate in all light conditions and validate use case conditions
- GPS used as ground truth

Below: IR Camera feed
Left: Visual Camera feed

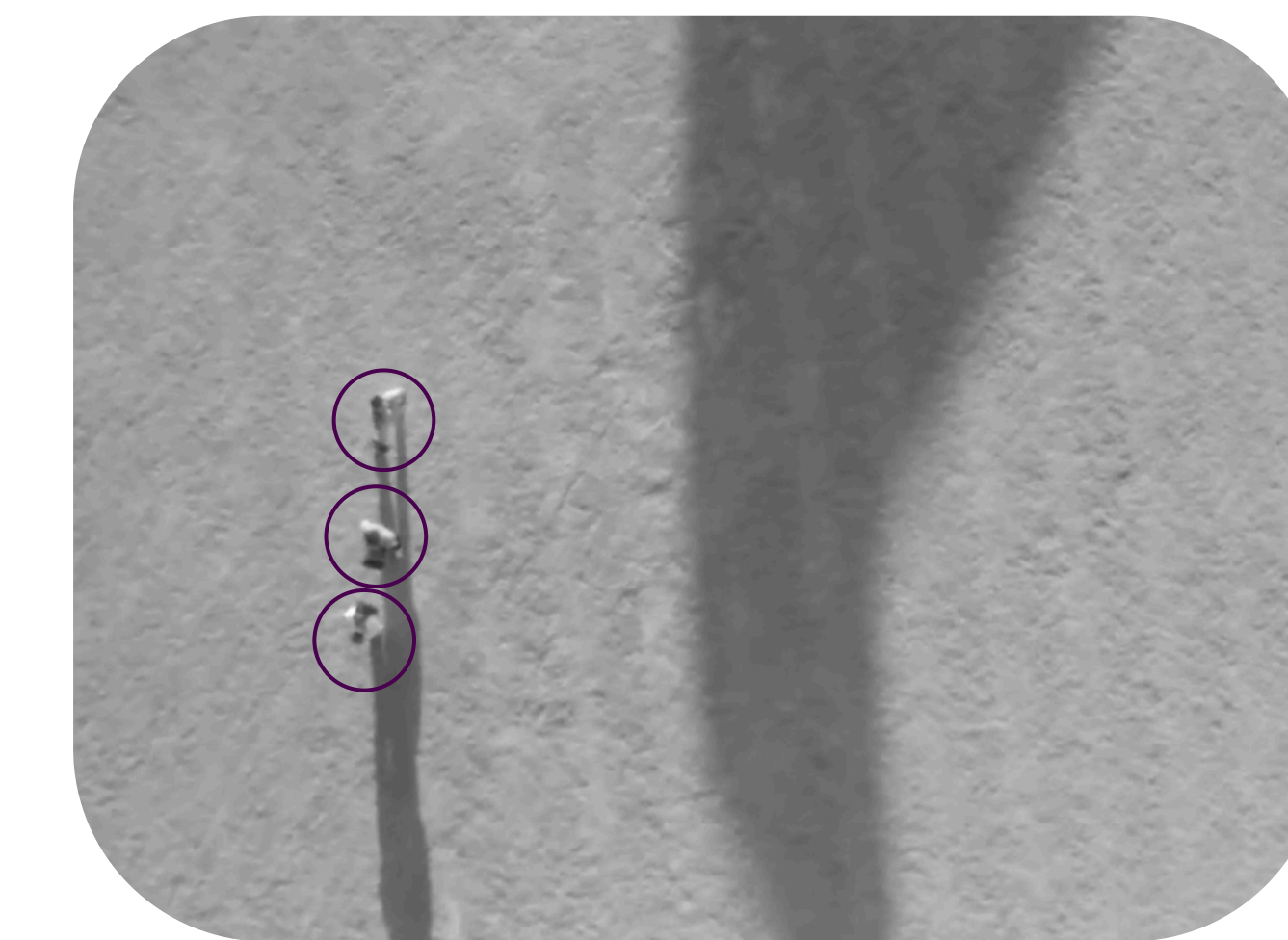

- Flown 30-40 feet above ground, able to track features such as lampposts and people in both visual and thermal cameras
- Temperatures of all sensors are also recorded to monitor heat conditions within the payload

Calibration and Error Analysis

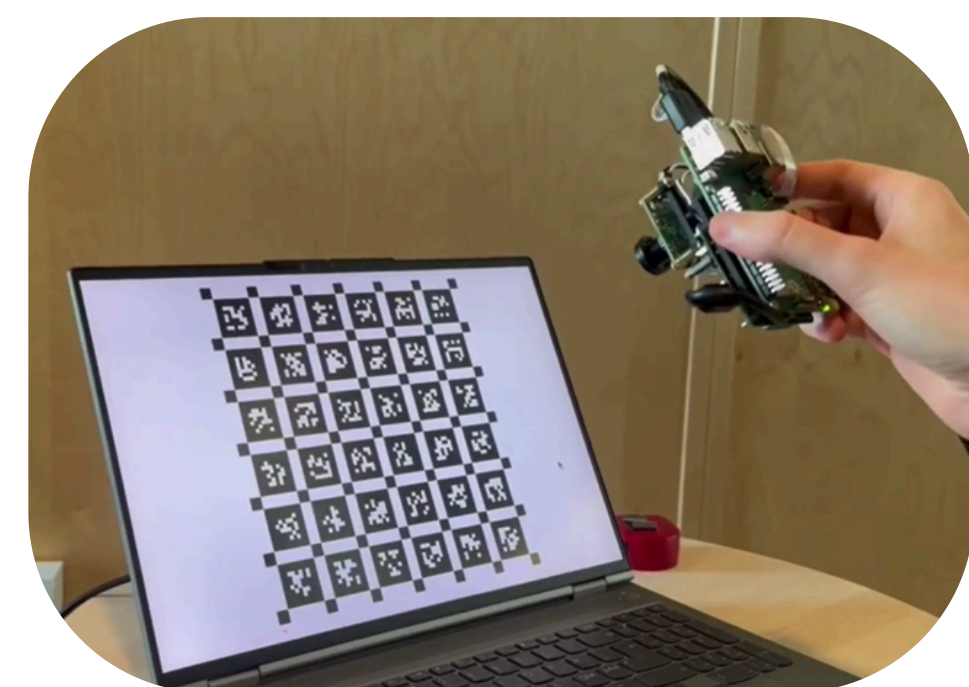

- Visual calibration uses April Grid pattern (left)
- Thermal heat circle targets for IR camera (right)

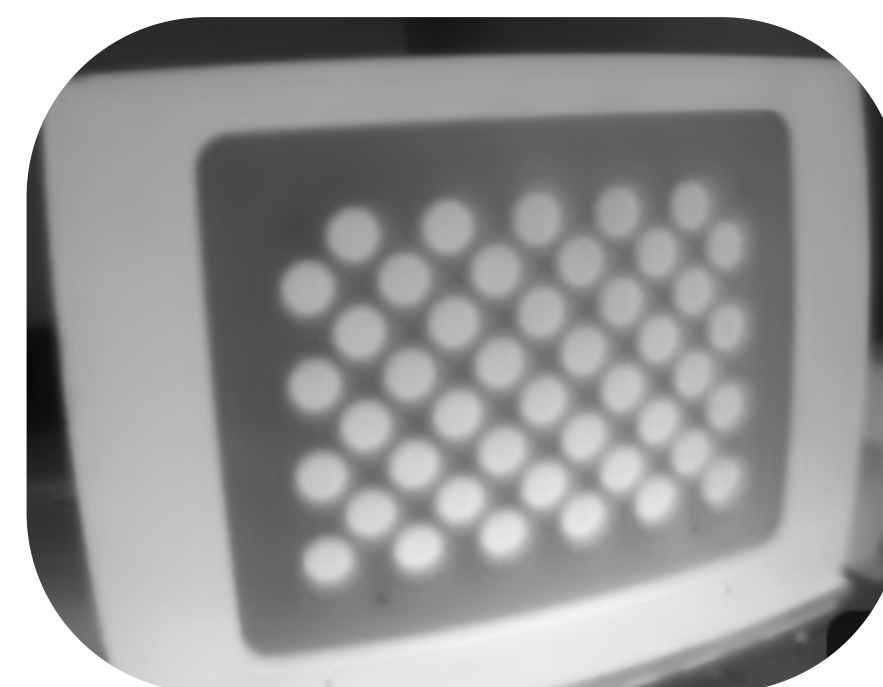

Metrics and Results

- Low Reprojection Error: **0.45 px**
- Spatial Validation: Camera-to-IMU distance (~4.36 cm) **matches reality**

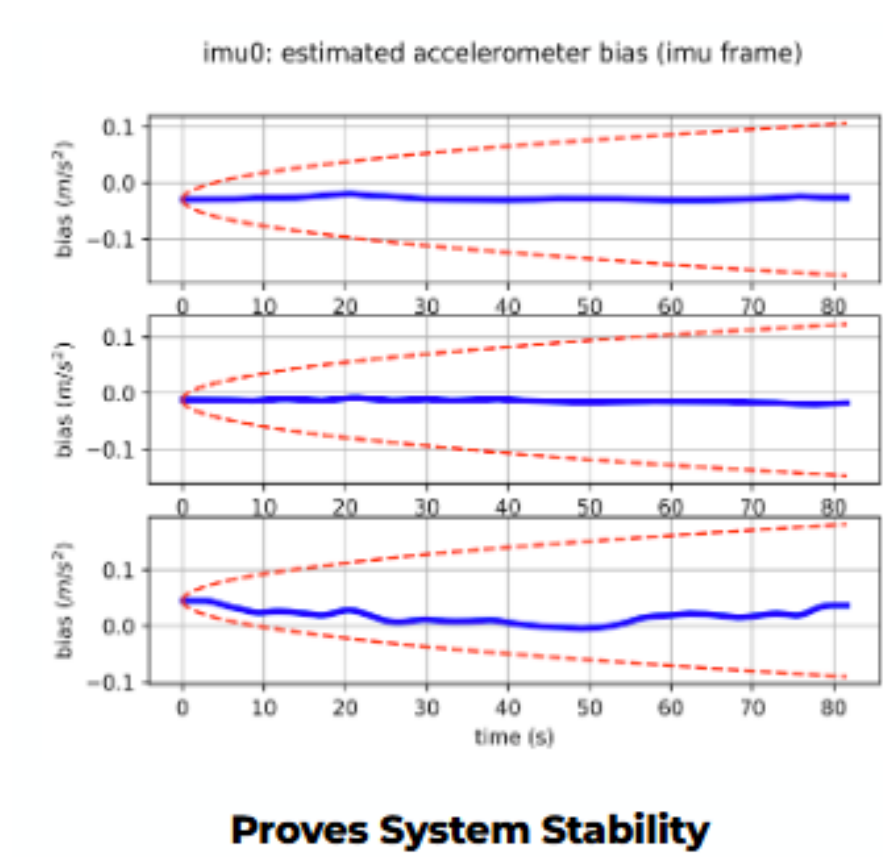
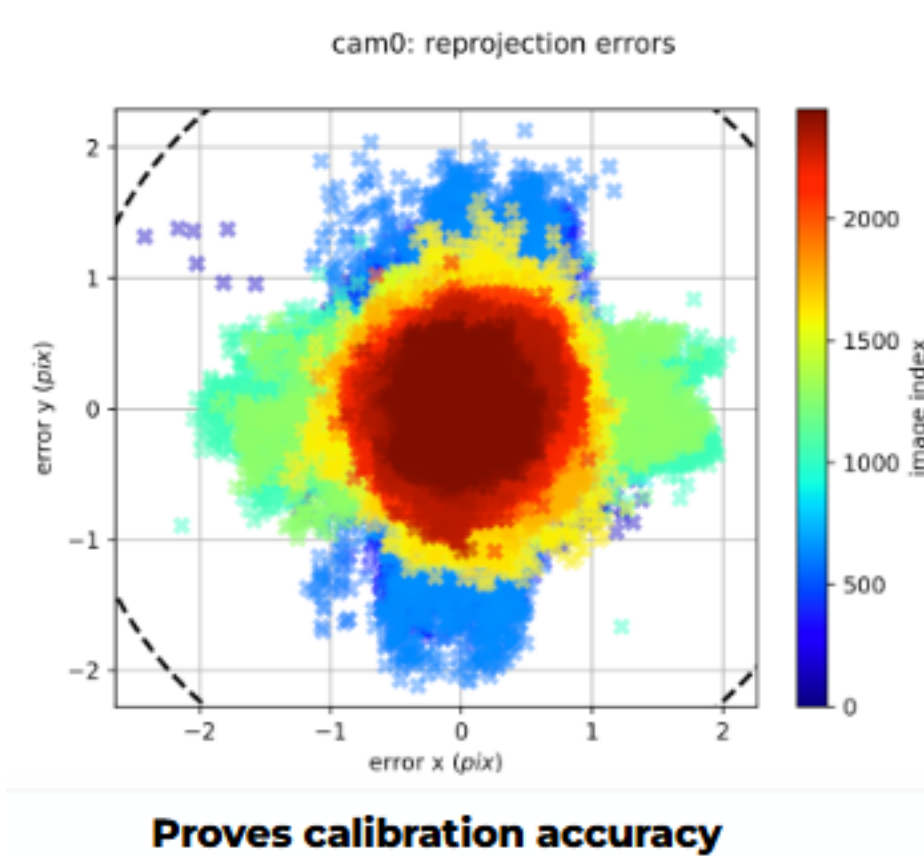
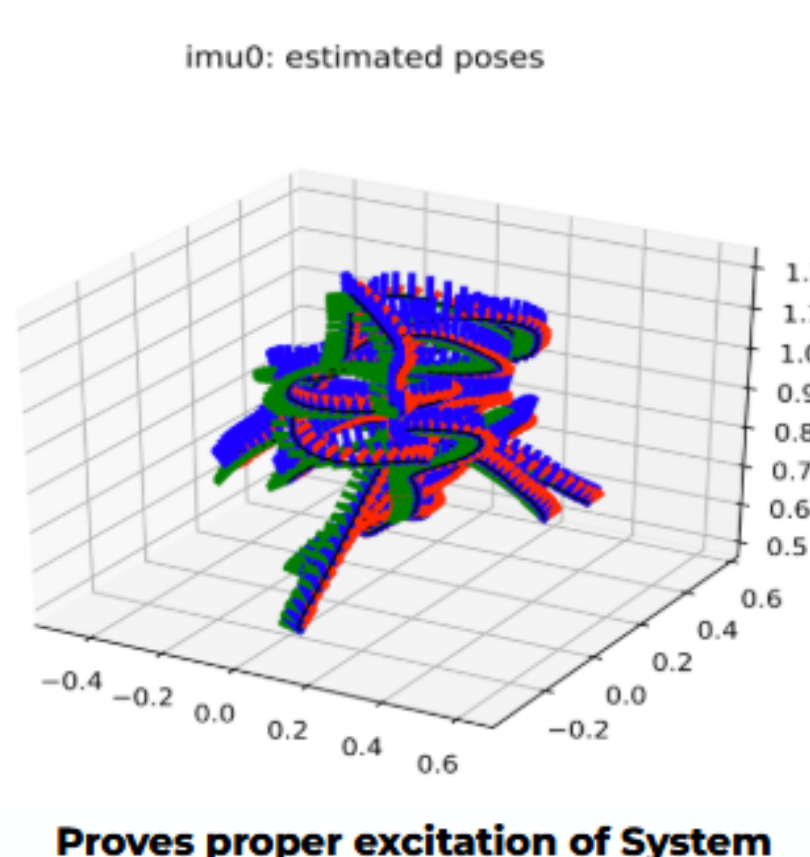

Power Tree

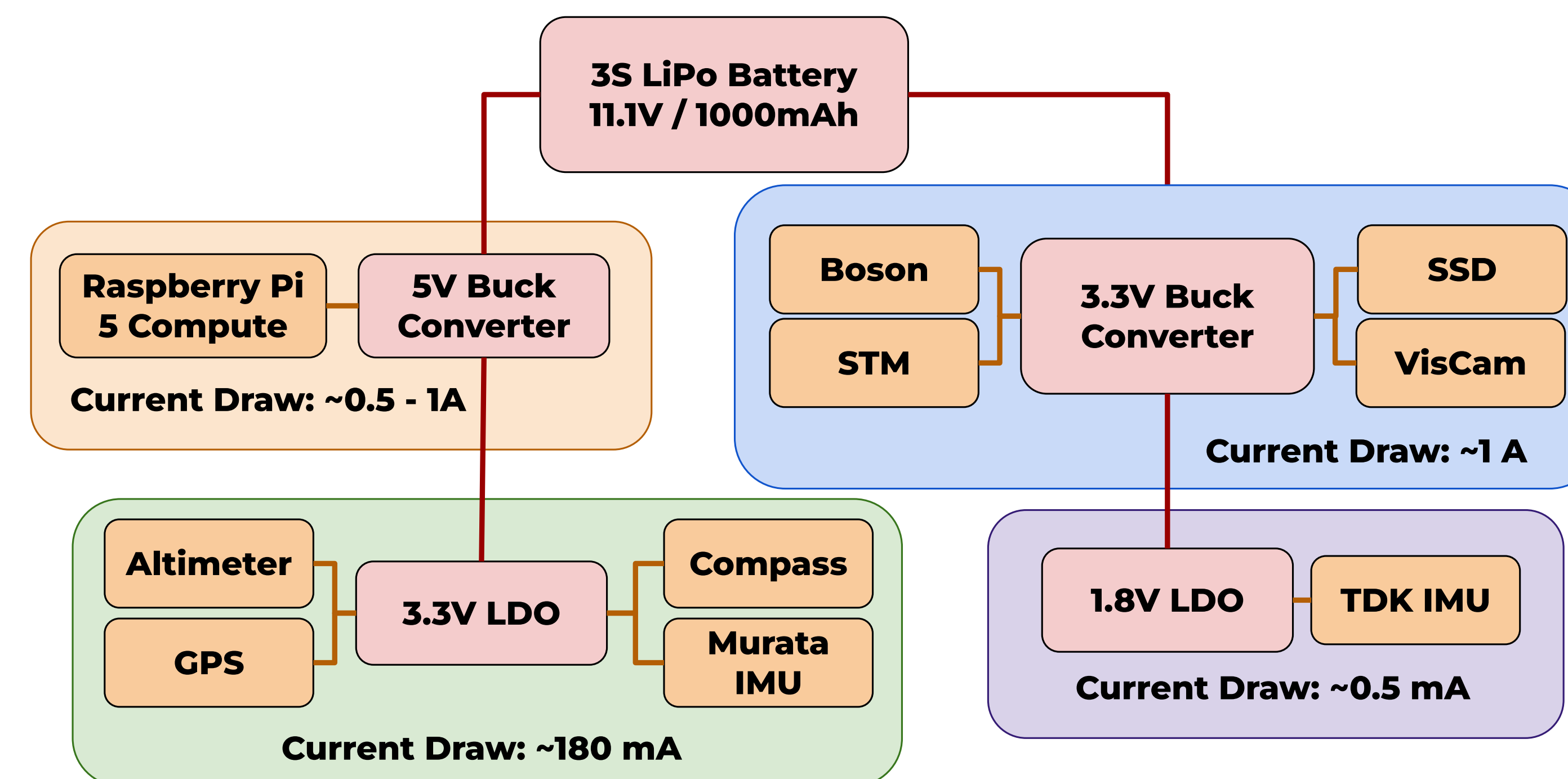

Actual Power Draw: Avg. 7W; Peak 10W
11.1 Wh Battery ~ 1 hr max flight time

Future Improvements

- 1. Real-Time Navigation:** Our system requires post-processing to determine the drone's location. Future iterations should focus on processing the data in real time and sending the position to the drone's flight controller for real-time and potentially autonomous navigation.
- 2. Drawing power from the drone:** Currently, the payload draws power from an external battery. Since this adds additional weight and heat, being able to draw power from the drone instead would be ideal.
- 3. ASA housing:** In search and rescue scenarios, the drone should be able to handle a wide temperature range. Currently, the payload is made with PLA due to accessibility but ideally, it should be made with ASA for increased durability and heat-tolerance.



Acknowledgements:

UCSB: Prof. Ilan Ben-Yaacov, Prof. Ted Bennett, Prof. Tyler Susko, Paul Hoff
FLIR: Ryan Stevenson, Ryan Helling, Jeff Haller, Sylvia Madhow

UC SANTA BARBARA
Robert Mehrabian
College of Engineering