

Background

With the rise of 5G and demand for other high-power RF applications, the need for new fast switching, high performance amplifiers is greater than ever. The efficiency of power amplifiers (PA) must increase to reduce power consumption while maintaining linearity to prevent out-of-band leakage and signal distortion. Robust PA designs alone do not guarantee linearity for high power inputs. Digital predistortion (DPD) is one solution that can maintain linearity at high power.

Overview / Design Specs

In order to optimize the linearity and efficiency of our RF power amplifier, we designed a Class B power amplifier which optimized efficiency at the cost of linearity. A Digital Predistorter (DPD) algorithm was developed alongside our amplifier to improve the linearity while keeping the high efficiency of our amplifier.

PA specifications:

- 10 W output
- 1 GHz frequency
- 66.9% efficiency
- 28 V supply

Block Diagram and Hardware

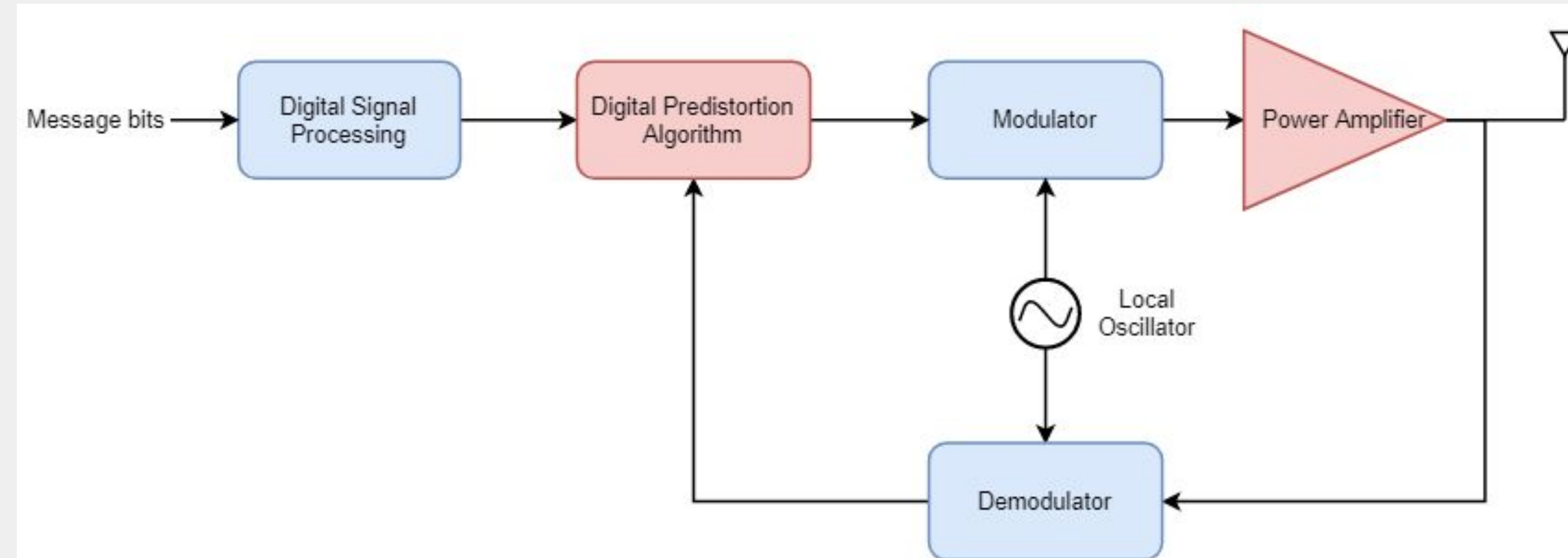

Cree GaN HEMT

High Electron Mobility Transistor used in the power amplifier.

LimeSDR

Software-Defined Radio used to send and receive the signals for the DPD.

RF Power Amplifier

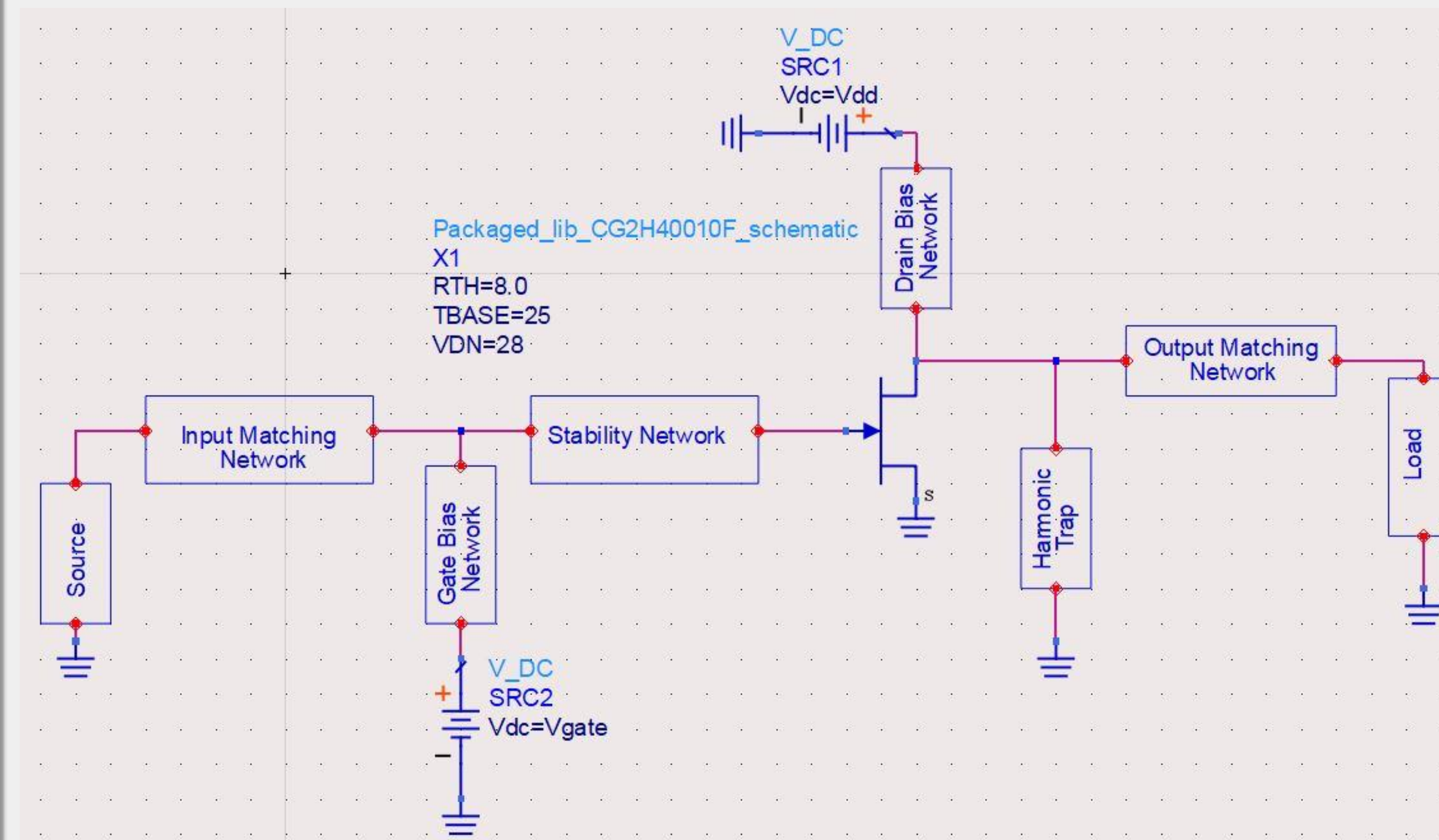

Class B Power Amplifier Schematic

- Designed and simulated in Advanced Design System using GaN HEMT model provided by Wolfspeed.

Class B Amp PAE vs Input Power

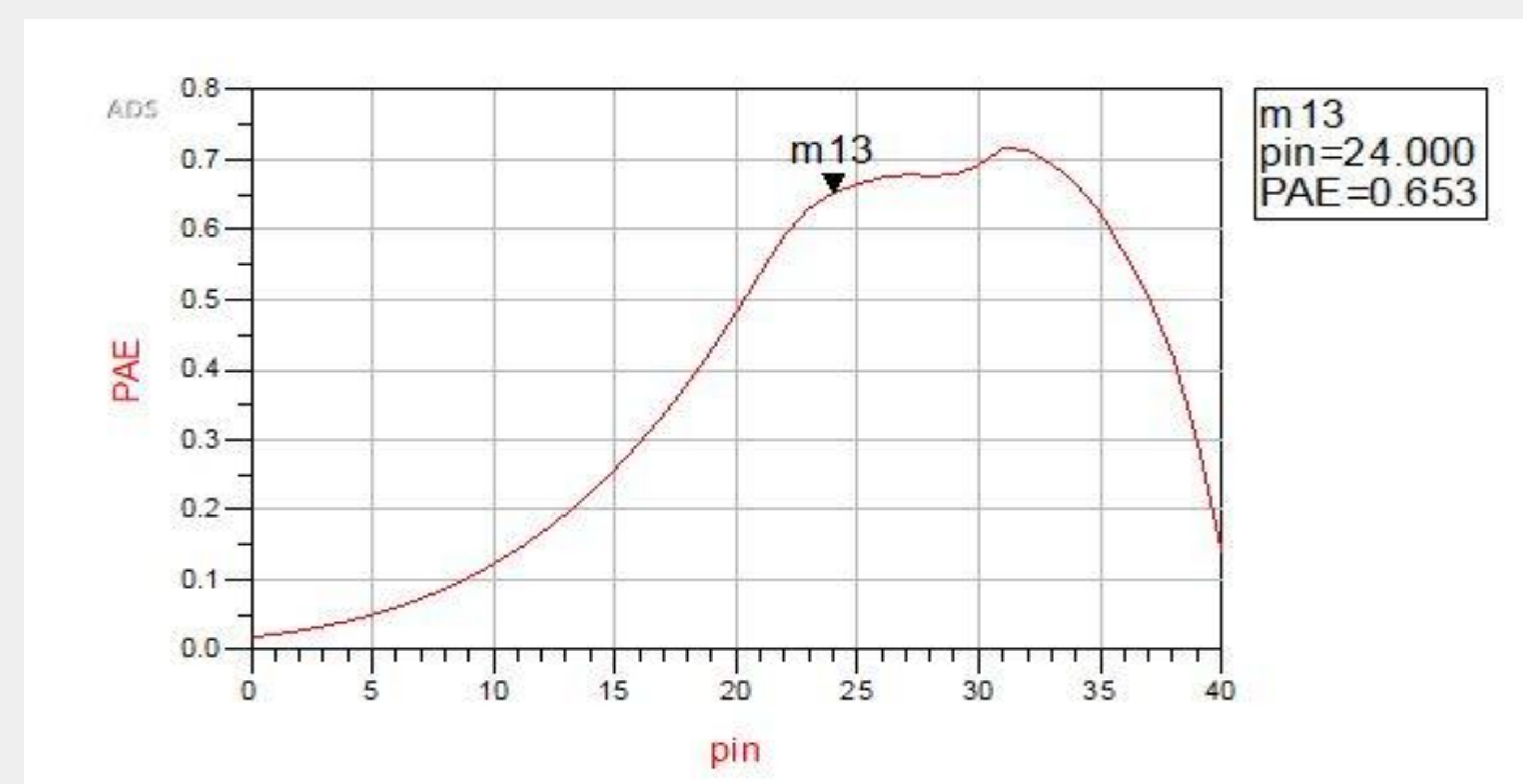

Results:

I_{DC}	V_{DC}	P_{Load}	Efficiency
0.554 A	28 V	10.373 W	66.9%

Digital Predistortion

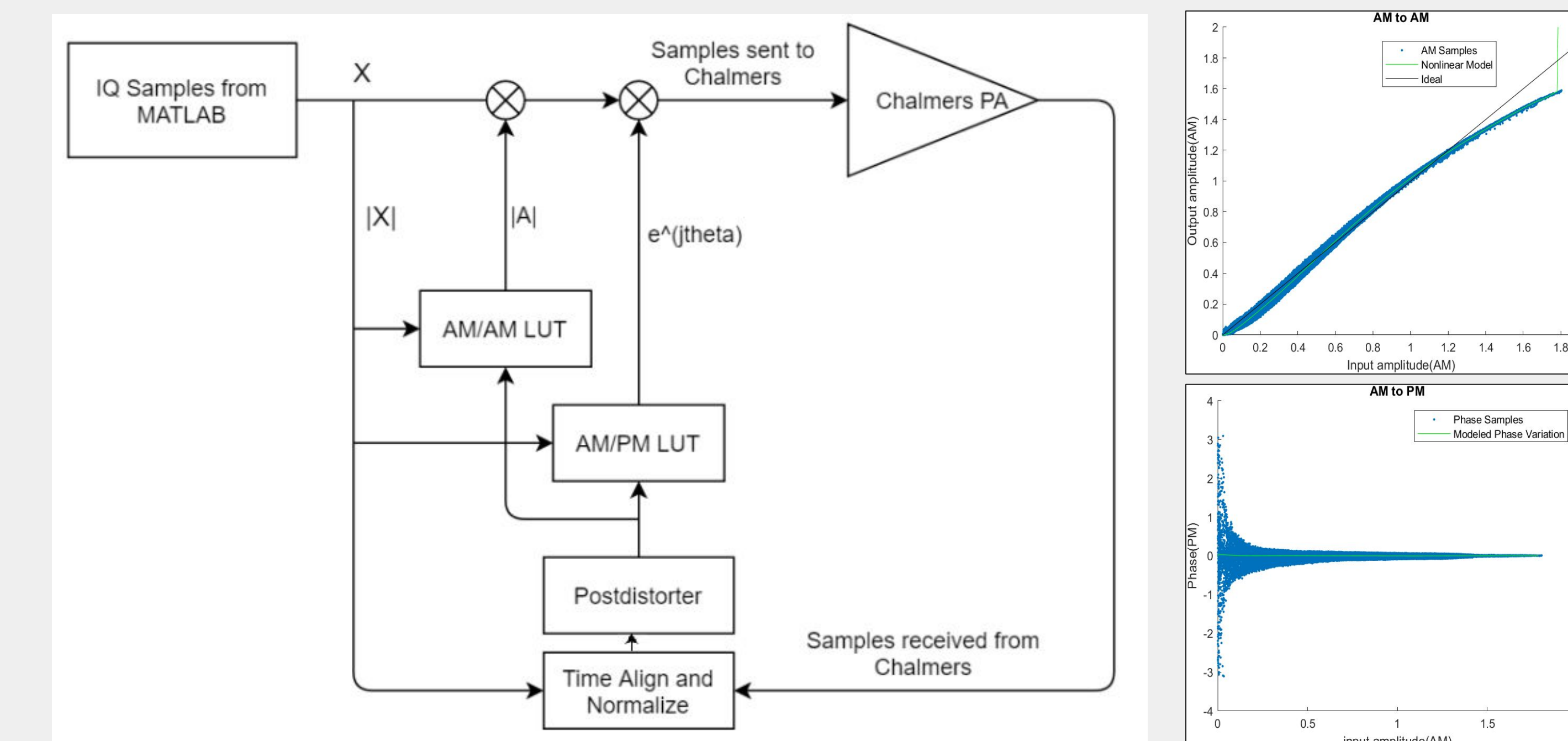

- Linearizes distortion from power amplifier
- Block programming on GNURadio
- Lookup table (LUT) based algorithm on MATLAB

Output After DPD

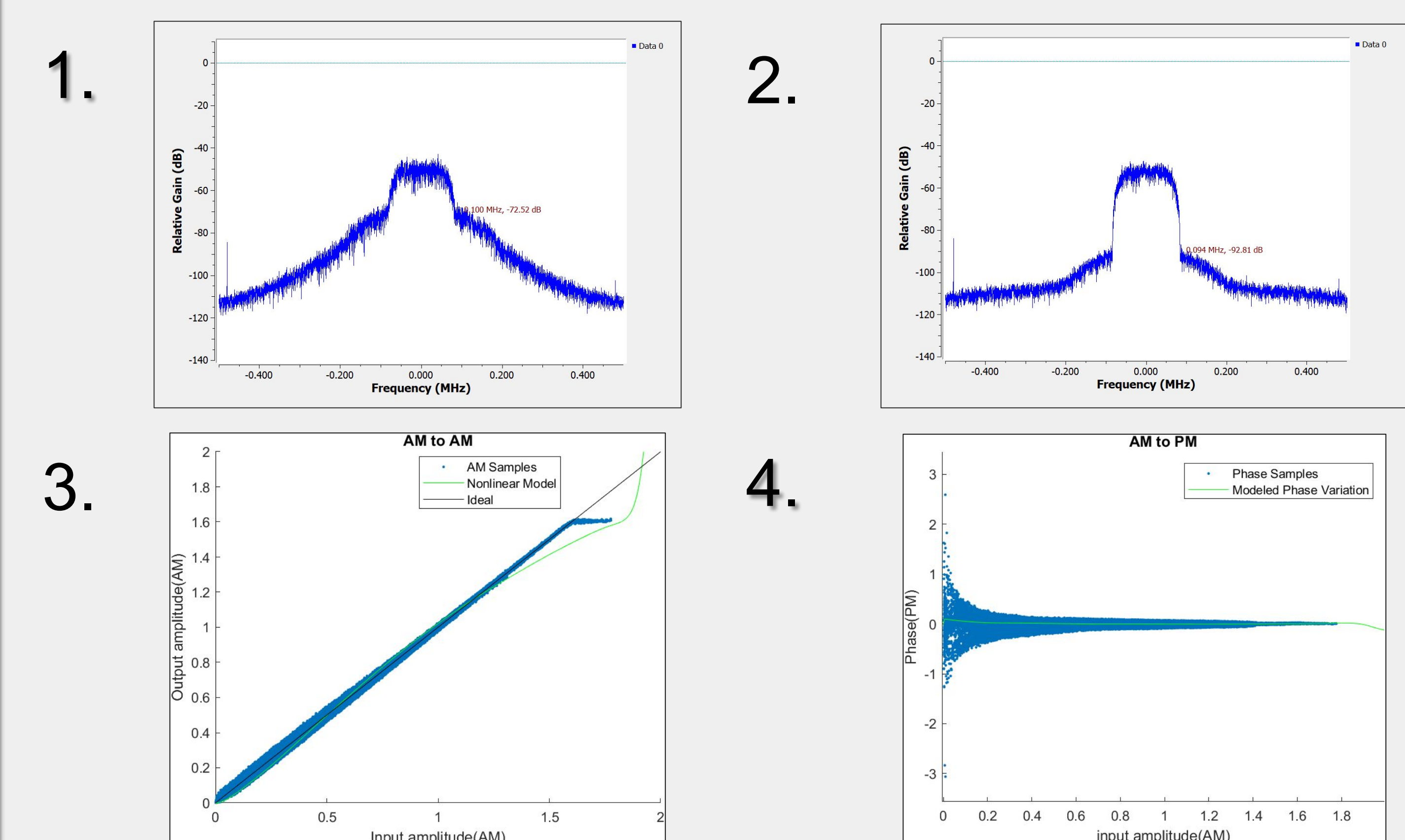

- Figure 1 shows PA output spectrum without DPD.
- Figure 2 shows PA output spectrum with DPD.
- Figure 3 shows corrected amplitude samples
- Figure 4 shows corrected phase samples