

Background

In our everyday life, we are surrounded by numerous motors. For years, the way by which motors are run hasn't changed at all despite new technology being developed that could make them more efficient.

But Cyclus brings transformation. We have designed a new test platform and driver algorithm that will improve performance of modern motor drives. Cyclus is concentrating on this new motor driving technique and this new material that would both increase the efficiency and optimize the size of motors.

Overview

- FPGA-based control and monitoring system for the motor operation.
- Optimized for high speed Gallium Nitride based inverters
- Synchronizes the motor's real-time position with its drive current to decrease the energy consumption.
- Implements Sigma-Delta Modulation for Control system of the DC brushless motor.
- Allows for reduced size and weight of control module.

System Diagram

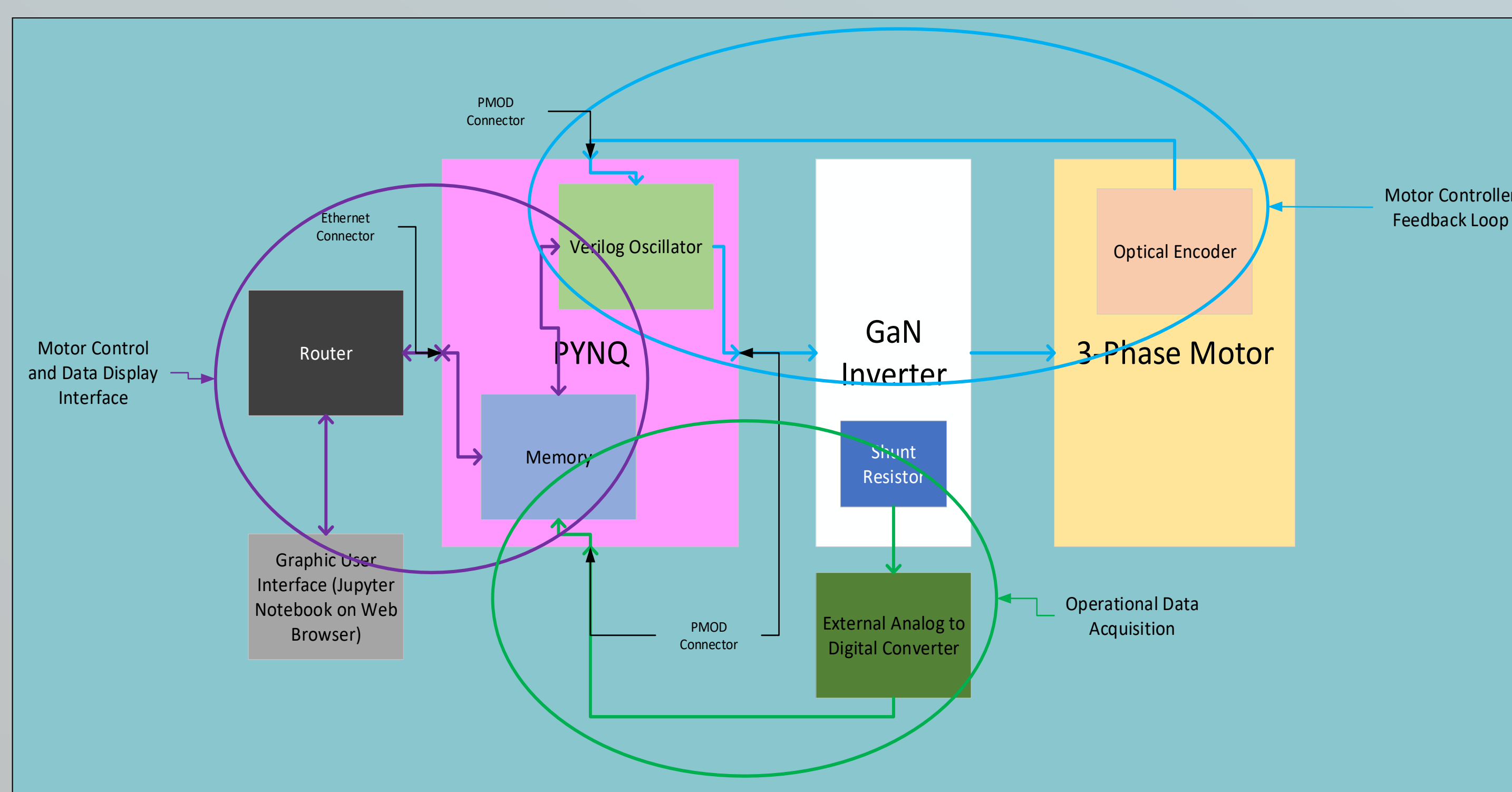

Operation Demo

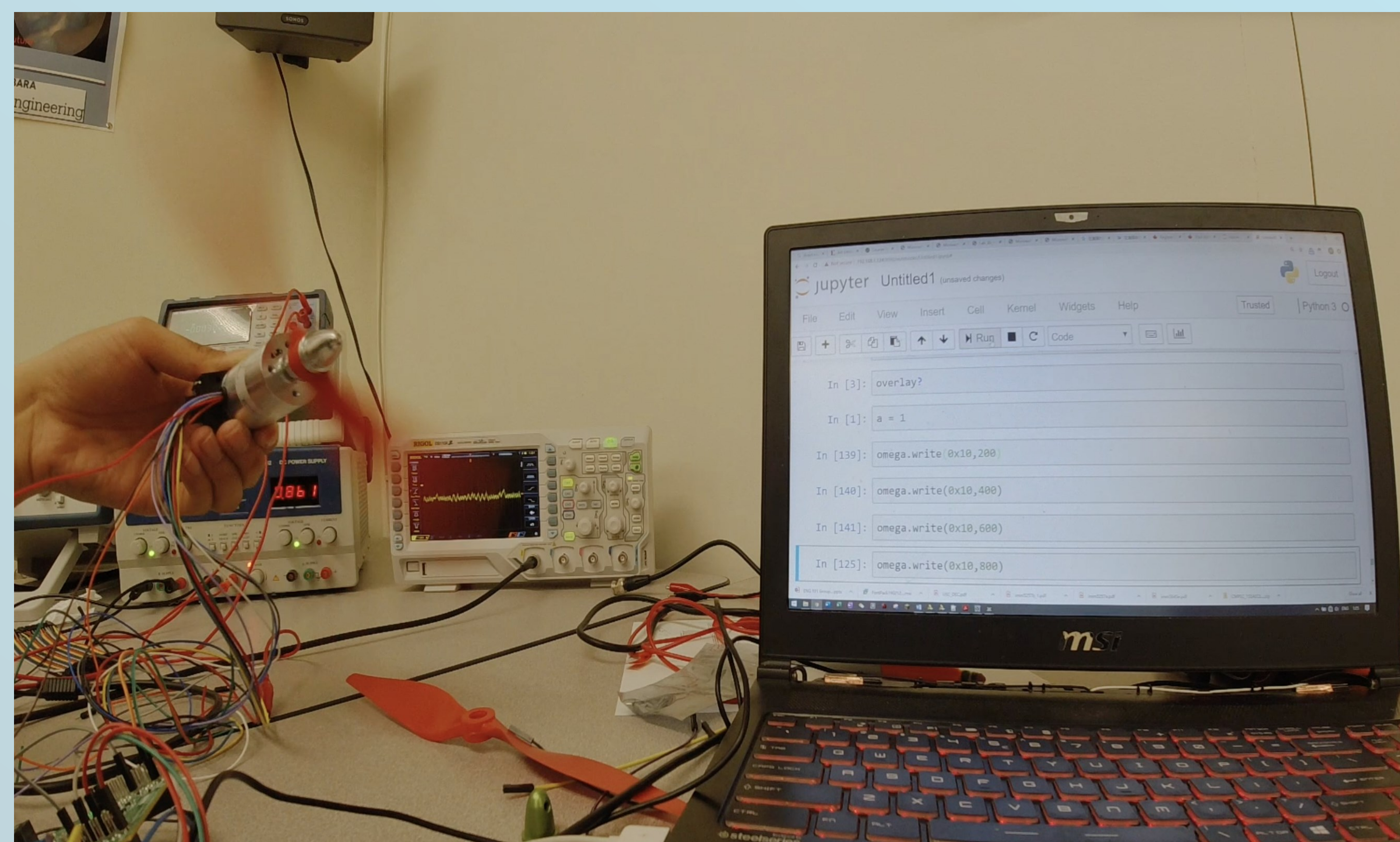

In the demo, we used the Jupyter Notebook, a python-based user interface to control the speed of the motor wirelessly with our new algorithm which drives a GaN inverter

Hardware / Key Components

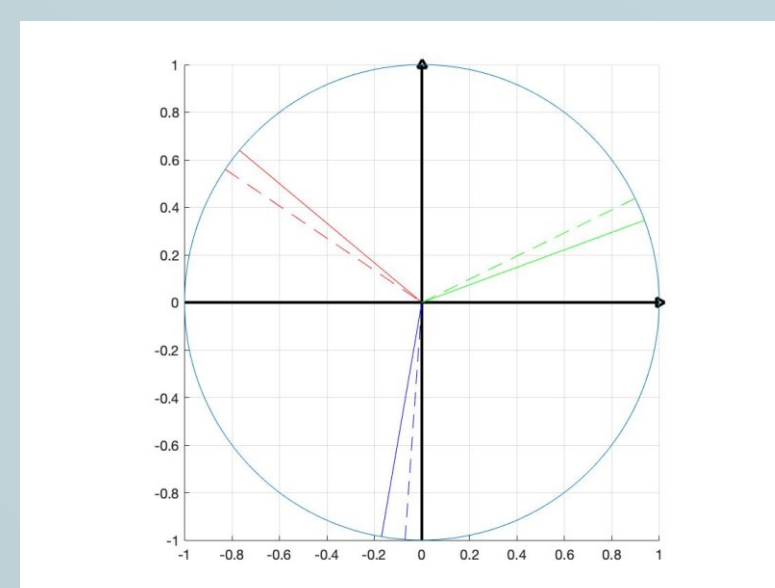

Three-phase Oscillator

With the Sigma-delta modulation, our three-phase oscillator could directly give DCBL motor driving currents

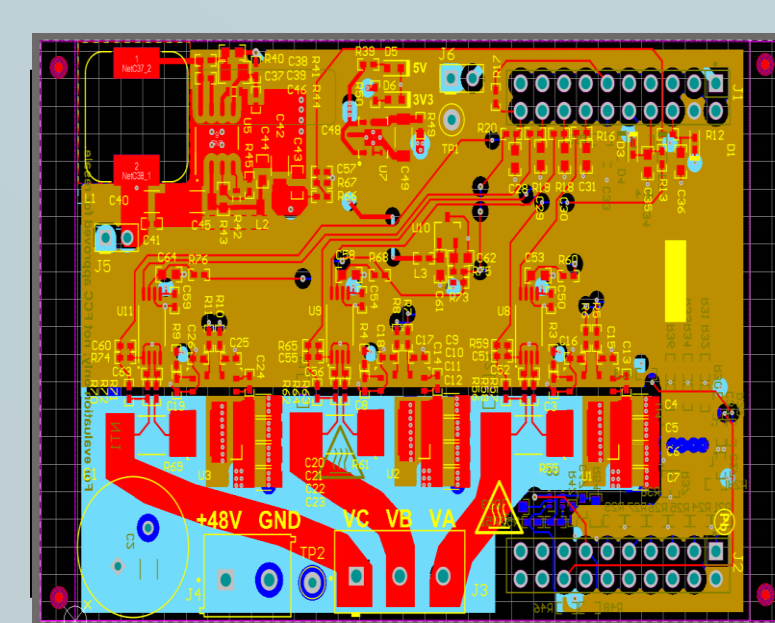

GaN Inverter

The newly designed GaN inverter not only has a faster switching speed but also can monitor the motor's operation through shunt resistors.

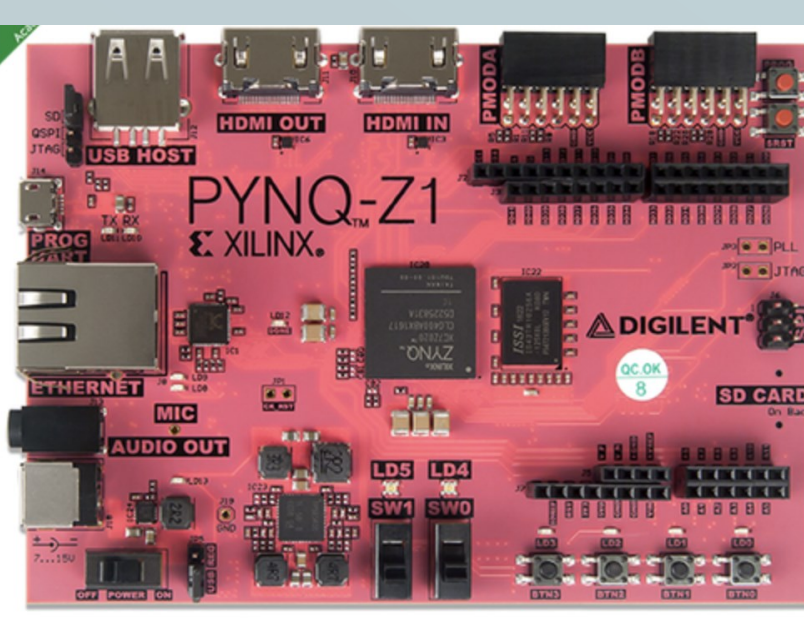

PYNQ FPGA Board

This is where all the designs are implemented. With an FPGA chip and a built in Python interface, we can control the motor easily

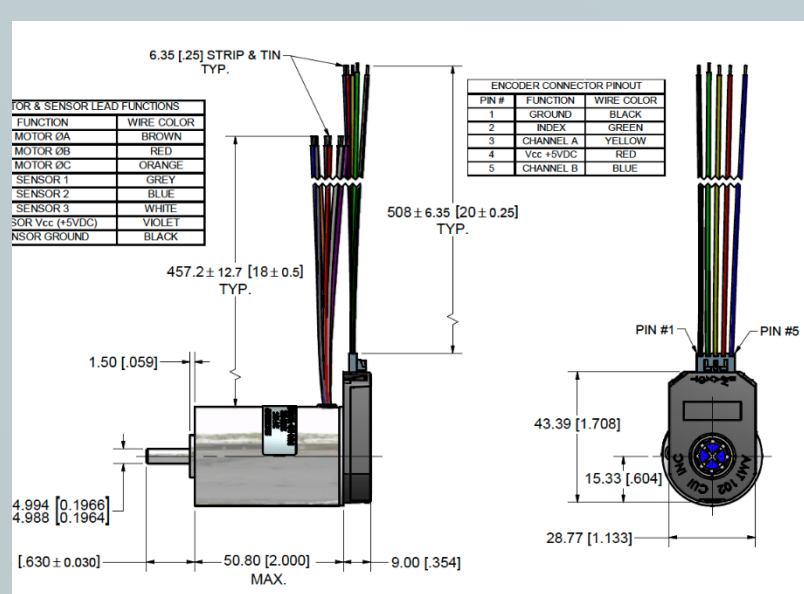

Motor with Quadratic Encoder

48 watts brushless DC motor suitable for testing our platform

Control System Implementation

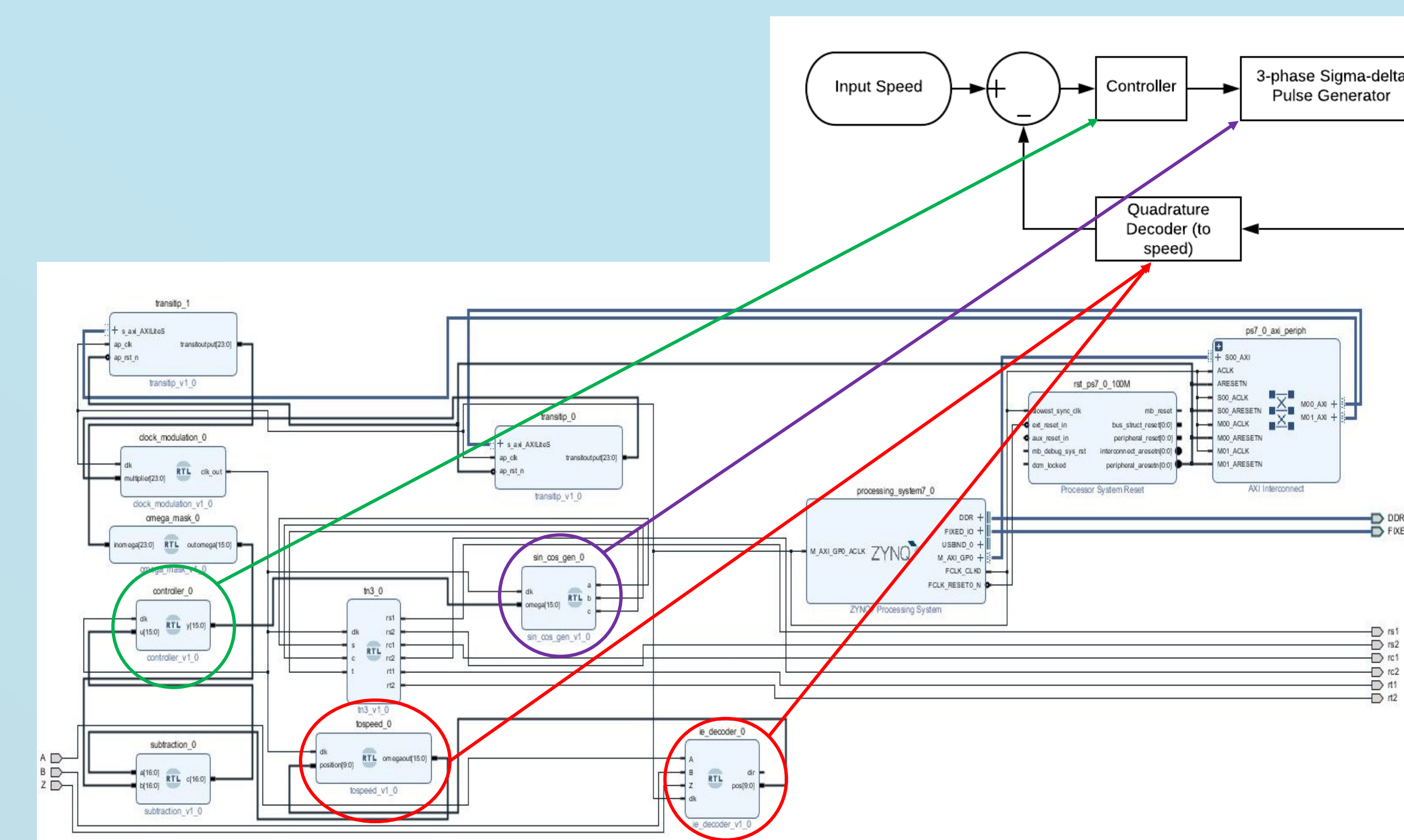

This is the feedback control system design and its Vivado implementation on the PYNQ board. Blocks in red circle represent one of our breakthroughs: to directly convert the real-time position data into speed data without any multiplication or diversion operations in hardware description language.

Future Improvement

As for the current progress, we have several possible future improvements.

- Improve the user-interface for the system and add real-time monitor functionality in the interface, allowing users to record the real-time current and motor speed in operation.
- Calculate the efficiency of the system, which is the ratio of the dynamic power of the motor operation to the electrical power supplied to the motor.
- Calculate the efficiency of the whole system with controller and without controller and compare them.
- With sufficient efficiency and speed data, tune the cutoff frequency of the PI (proportional-integral) controller to achieve higher efficiency.

Acknowledgements:

Our sincere gratitude to our Professor Forrest Brewer, Joao Hespanha, Ilan Ben-Yaacov, Yoga Isukapalli, Reza Abdoolee our mentor Dr. Joseph Poverelli, our TA Evan Blasband, Blake Diamond, Erik Rosten and all the colleagues at Laritech!