

Cloud Control

Fall Quarter Design Review

A dark blue diagonal shape that starts from the bottom left corner and extends towards the top right corner, covering the bottom half of the slide.

Team

Development Team

- Andrew Thompson
 - Project Lead
- Reed Taylor
 - PCB Design
- Brent Morada
 - Wireless Communications
- Anna Lee
 - Audio Processing
- Jair Santiago Carranza
 - Amplifier/Speaker System

Team Sponsor



AeroVironmentTM

- Phil Tokumaru
 - AeroVironment Project Advisor

Project Vision, Applications

- Crowd control system using a drone equipped with a speaker
- Relay important messages to a target audience without being physically present
- Stretch goal: two-way communication

System Architecture

- Project Consists of two main components:
 - Ground control system
 - Drone with receiver module

Ground Control System

- Application on desktop or mobile client
- Records the user via a microphone
- Transmits the digital audio samples to the drone receiver over NRF24 wireless module

Drone Receiver Module

- Drone with mounted PCB and speaker system
- Flies 5-10 feet over target audience
- Receives digital audio samples from client, converts to analog, and outputs to speakers

Block Diagram

Audio Cartridge

Module fitted to the Drone Platform to output the audio stream from the base station.

UAV
(Yuneec
Typhoon H Pro
Drone)

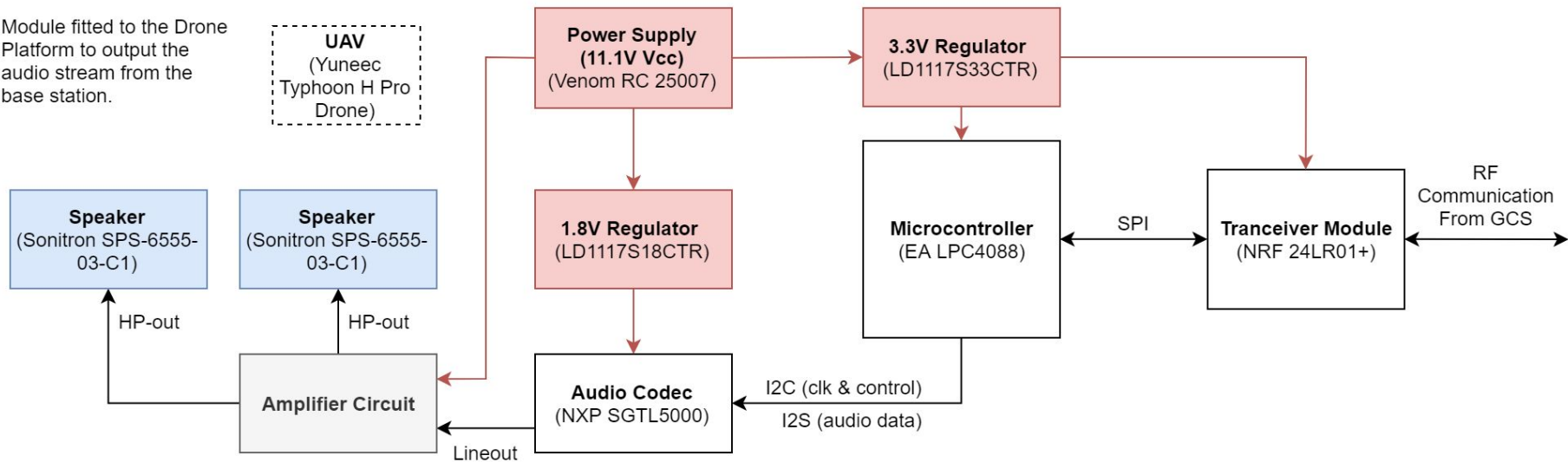

Ground Control Station

Ground station used to broadcast audio streams to the drone platform

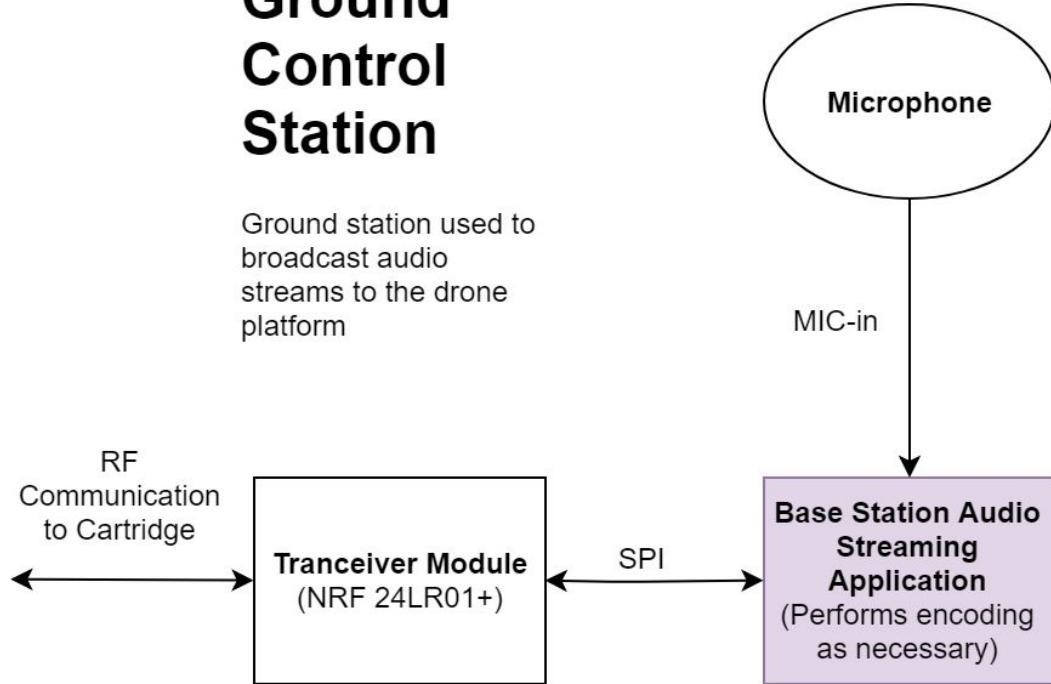

PCB Schematic

PCB Layout

Bill of Materials

LPC4088 Microcontroller	\$14
SGTL5000 Audio Codec	\$4
3.3V and 1.8V Voltage Regulators	\$1
Main Crystal	\$2
Headers, Adaptors, Capacitors, and Resistors	\$6
Sonitron Speakers	\$50
Amplifier Components	\$30
Venom Power Supply and Charger	\$134
Yuneec Typhoon H Pro Hexacopter Drone	\$900
TOTAL COST	\$1,141

Drone Choice



- Yuneec Typhoon H Pro
 - Can carry ~ 4lbs
 - Relative operating loudness around Phantom 4
 - Enough space to fit PCB, battery and piezoelectric speaker

Prototyping Progress

- **Audio Streaming**

- Successful audio streaming from end host (desktop) to Raspberry Pi using portaudio library
- Next goal is to port this code to the LPC4088 and alter the packetization to work with the NRF wireless module
- May run into issues with installing/compiling portaudio library on LPC4088

Prototyping Progress

- **Wireless Communication (NRF24)**
 - Demonstrated NRF24 Communication between a Raspberry Pi and an Arduino Uno
 - Starting port of the NRF24 library to LPC4088 for use between our board and our GCS
 - Like the audio streaming, a primary concern will be effectively replicating the NRF24 libraries functionality

Prototyping Progress

- **Audio Processing (SGTL5000 Codec)**
 - Successfully sent raw/uncompressed audio files (.wav) over I2S from an SD card on an arduino board to the headphone-out on the audio codec with dB gain
 - Starting to port interfacing code over to NXPpresso to interface the codec with the LPC4088
 - May run into trouble porting SPI interfacing over to I2C (our original plan) and/or replicating libraries

Prototyping Progress

- **Speaker and Amplifier System**

- *Venom Fly* power supply will power the drone's components and speaker system while in flight.
- *SPS-6555-03* piezo speakers have been decided on.
- *PAA-STEPUPBTL-01* could not be acquired in the US. We were able to find the design but must be implement it using different components.
- The parts for this amplifier have been decided on and will be verified by Brandon for prototyping on a breadboard.

Moving Forward

- Finalize Layout and submit to PCB manufacturer
- Port NRF communications library to LPC4088
- Port audio codec driver to LPC4088
- Modify our C audio streaming program to work under LPC4088 memory constraints
- Finish amplifier construction and test with PCB and speakers
- Create housing for components to attach to drone

Thanks to:

- Yogananda Isukapalli, Capstone Instructor
- Brandon Pon, TA
- Carrie Segal, TA
- Phil Tokumar, AeroVironment Project Advisor
- AeroVironment, Inc, Project Sponsor

Q & A